

# *Actel® Getting Started*

*User's Guide*

R1-2003



***For more information about Actel's products, call 888-99-ACTEL  
or visit our Web site at <http://www.actel.com>***

**Actel Corporation** • 955 East Arques Avenue • Sunnyvale, CA USA 94086

U.S. Toll Free Line: 888-99-ACTEL • Customer Service: 408-739-1010 • Customer Service FAX: 408-522-8044

Customer Applications Center: 800-262-1060 • Customer Applications FAX: 408-739-1540

**Actel Europe Ltd.** • Daneshill House, Lutyens Close • Basingstoke, Hampshire RG24 8AG • United Kingdom

Tel: +44 (0)125-630-5600 • Fax: +44 (0)125-635-5420

**Actel Japan** • EXOS Ebisu Bldg. 4F • 1-24-14 Ebisu Shibuya-ku • Toyko 150 • Japan

Tel: +81 (0)334-457-671 Fax: +81 (0)334-457-668

5029123-4



---

# ***Actel® Getting Started***

*User's Guide*



*Windows® and UNIX® Environments*

---

## **Actel Corporation, Sunnyvale, CA 94086**

© 2003 Actel Corporation. All rights reserved.

Printed in the United States of America

Part Number: 5029123-4

Release: January 2003

No part of this document may be copied or reproduced in any form or by any means without prior written consent of Actel.

Actel makes no warranties with respect to this documentation and disclaims any implied warranties of merchantability or fitness for a particular purpose. Information in this document is subject to change without notice. Actel assumes no responsibility for any errors that may appear in this document.

This document contains confidential proprietary information that is not to be disclosed to any unauthorized person without prior written consent of Actel Corporation.

Trademarks

Actel and the Actel logotype are registered trademarks of Actel Corporation.

Adobe and Acrobat Reader are registered trademarks of Adobe Systems, Inc.

Cadence is a registered trademark of Cadence Design Systems, Inc.

Mentor Graphics is registered trademark of Mentor Graphics, Inc.

Sun and Sun Workstation, SunOS, and Solaris are trademarks or registered trademarks of Sun Microsystems, Inc

Synopsys is a registered trademark of Synopsys, Inc.

Verilog is a registered trademark of Open Verilog International.

Viewlogic, ViewSim, ViewDraw and SpeedWave are trademarks or registered trademarks of Viewlogic Systems, Inc.

Exemplar Spectrum is a register trademark of Mentor Graphic, Inc.

Windows is a registered trademark and Windows NT is a trademark of Microsoft Corporation in the U.S. and other countries.

UNIX is a registered trademark of X/Open Company Limited.

All other products or brand names mentioned are trademarks or registered trademarks of their respective holders.

---

# Table of Contents

	<a href="#">Introduction</a>	7
	Document Organization	7
	Document Assumptions	8
	Document Conventions	8
	Your Comments	8
	Actel Manuals	9
	Online Help	9
<b>1</b>	<a href="#">Designer Series Overview</a>	11
	Designer	11
	ACTgen Macro Builder	14
	Silicon Expert	14
	Designer Maintenance	15
	Schematic-Based Design Methodology	15
	HDL Synthesis-Based Design Methodology	15
<b>2</b>	<a href="#">Actel Design Flows</a>	17
	Schematic-Based Design Flow Illustrated	17
	Schematic-Based Design Flow Overview	18
	HDL Synthesis-Based Design Flow Illustrated	21
	HDL Synthesis-Based Design Flow Overview	22
<b>3</b>	<a href="#">Design Considerations</a>	25
	Naming Conventions	25
	Hierarchical Designs	29
	Multiple Sheet Designs	29
	Actel Libraries	29
	Adding Power and Ground	29
	Adding a Global Network	30
	Using ProASIC Global Routing Resources	34
	Combinability	34
	Net Loading	43
	Logic and I/O Utilization	44

Adding Properties . . . . .	44
ALSPIN . . . . .	49
Generating a Top-Level Symbol . . . . .	54
Entering Constraints for Timing Driven Place-and-route . . . . .	54
Estimating Pre-Layout Timing . . . . .	54
Adding ACTgen Macros . . . . .	56
<b>4 ProASIC Design Considerations . . . . .</b>	<b>57</b>
Design Optimization . . . . .	57
Design Integrity . . . . .	57
Design Hints . . . . .	58
Implementing Memories . . . . .	59
<b>A Product Support . . . . .</b>	<b>61</b>
Actel U.S. Toll-Free Line . . . . .	61
Customer Service . . . . .	61
Actel Customer Technical Support Center . . . . .	61
Guru Automated Technical Support . . . . .	62
Web Site . . . . .	62
Contacting the Customer Technical Support Center . . . . .	62
Worldwide Sales Offices . . . . .	64
<b>Index . . . . .</b>	<b>65</b>

---

# Introduction

The *Getting Started User's Guide* contains information for using the Designer Series Development System software to create designs for, and program, Actel devices.

This manual includes information about the Designer software, which allows you to import a netlist generated from a third-party CAE tool, place and route the design, perform static timing analysis, extract timing information, estimate power consumption, and generate a programming file to program an Actel FPGA.

This manual also refers to other Actel documents that contain additional information, including CAE software interface guides and simulation guides with specific information about using CAE tools with the Designer Series Development System.

## Document Organization

The *Getting Started User's Guide* is divided into the following chapters:

**Chapter 1 - Designer Series Overview** gives an overview of the programs contained in the Designer Series Development system software.

**Chapter 2 - Actel Design Flows** illustrates and describes the design flow for creating Actel designs using the Designer Series software and third-party CAE tools.

**Chapter 3 - Design Considerations** contains useful information and procedures about creating designs using the Actel Designer Series software.

**Chapter 4 - ProASIC Design Considerations** contains information and procedures to assist you in creating Actel designs with ProASIC devices.

**Appendix A- Product Support** provides information about contacting Actel for customer and technical support.

## Document Assumptions

The information in this manual is based on the following assumptions:

1. You have installed the Designer Series software.
2. You are familiar with UNIX workstations and UNIX operating systems, or with PCs and Windows operating environments.
3. You are familiar with FPGA architecture and FPGA design software.

## Document Conventions

The following conventions are used throughout this manual.

The contents of a file is formatted as follows:

```
file contents
```

All references to “ProASIC” in this document include members of both the ProASIC and ProASIC<sup>PLUS</sup> device families.

The <act\_fam> variable represents an Actel device family. To reference an actual family, substitute the name of the Actel device when you see this variable. Available families include the act1, act2 (for ACT 2 and 1200XL devices), ACT3, 3200DX, 40MX, 42MX, and 54SX, 54SX-A, eX, and Axcelerator.

The <vhd\_fam> variable represents Compiled VHDL libraries. To reference an actual compiled library, substitute the name of the library (act1, act2 (for ACT 2 and 1200XL devices), ACT3, A3200DX, A40MX, A42MX, A54SX, A54SX-A, eX, A500K/APA, and Axcelerator) when you see this variable. Compiled VHDL libraries must begin with an alpha character.

## Your Comments

Actel Corporation strives to produce the highest quality online help and printed documentation. We want to help you learn about our products, so you can get your work done quickly. We welcome your



feedback about this guide and our online help. Please send your comments to **documentation@actel.com**.

## Actel Manuals

Designer and Libero include printed and online manuals. The online manuals are in PDF format and available from Libero and Designer's Start Menus and on the CD-ROM. From the Start menu choose:

- Programs > Libero 2.3 > Libero 2.3 Documentation.
- Programs > Designer Series > R1-2003 Documentation

Also, the online manuals are in PDF format on the CD-ROM in the “/manuals” directory. These manuals are also installed onto your system when you install the Designer software. To view the online manuals, you must install Adobe® Acrobat Reader® from the CD-ROM.

The complete list of Designer Series manuals is available on the Actel website at <http://www.actel.com>.

## Online Help

The Designer Series software comes with online help. Online help specific to each software tool is available in Libero, Designer, ACTgen, ACTmap, Silicon Expert, Silicon Explorer II, and Silicon Sculptor.



---

# Designer Series Overview

The Designer Series Development System is an integrated suite of user-friendly tools for PC and Workstation environments that takes your design idea to working silicon quickly and easily. These tools are designed to satisfy the demands of today's design engineers to accelerate the system logic design process. This chapter describes the components and features of the Designer Series Development System.

## Designer

Designer is an interactive design implementation tool that can import designs created with popular third-party schematic and HDL CAE tools. Designer features fully automatic layout, pin fixing, a chip editor, netlist viewer, and a back annotation utility. Designer also includes Timer, which provides tools for timing driven place-and-route and static timing analysis. Designer also includes a power analysis tool that enables designers to estimate the power consumption of their design. These tools allow designers to define, layout (place-and-route), verify, and program high performance designs at high levels of utilization with improved productivity. Refer to the PinEdit, ChipEdit, Timer, SmartPower, Netlist Viewer, and *Designer User's Guide* documentation for additional information.

## Design Flow Manager

Designer uses a Design Flow Manager that graphically displays the completed steps of the design implementation process. Design Flow Manager also keeps track of information required to begin each step of the design's current status, and design source changes, so you don't have to.

Designer also uses demand-driven options that allow users to click any button in the Designer Main window to begin the design implementation process. Designer then prompts you through all of the necessary steps of the flow to complete the step that was selected.

## Compile

Compile reads in a netlist and compiles the design into an Actel database (ADB) file. Compile contains a variety of functions, including the Combiner and the Design Rule Checking functions, that perform legality checking and basic netlist optimization. Compile also checks

for netlist errors (bad connections and fan-out problems), removes unused logic (gobbling), and combines functions to reduce logic count and improve performance (combining or logic collapsing). In addition, Compile verifies that the design fits into the selected device. Refer to the *Designer User's Guide* for additional information.

**Accelerator Only:** Compile can also combine I/Os and Registers (where possible) on a per-I/O or design basis, depending on your requirements.

## Layout

Layout (place-and-route) takes the design netlist information, Pin information (optional), and Timing information (Timing Driven Layout only), and maps the information into the selected device. The Incremental Layout option enables designers to speed through design iterations. Two layout modes are supported, Standard and Timing Driven.

### **Standard Layout**

Standard layout is available for non-performance-critical applications. Standard layout maximizes the average performance for all paths and treats each part of a design equally for performance optimization, using net weighting (or criticality) to influence the results. Standard layout is the faster of the two modes.

### **Timing Driven Layout**

For timing critical designs, Timing Driven Layout uses timing requirements entered in Timer to constrain Layout. Timing Driven Layout is a fully automatic place-and-route utility that focuses resources to meet performance requirements.

**Accelerator Only:** There are five different placement effort levels available for Accelerator devices (marked from 1-5, five is the highest). The higher the effort level, the better chance you have of meeting your routability and performance goals. However, there is a corresponding increase in run time for the higher effort levels.

## ***Fuse (or Bitstream)***

Fuse generates the necessary files to program an Actel device. Fuse supports both Actel and Data I/O formats. Refer to the *Designer User's Guide* for additional information.

## ***User Tools***

The User Tools are Netlist Viewer, PinEdit, ChipEdit, Timer, SmartPower and Back Annotate. They enable you to view and modify pin locations and macro placement, and to evaluate the timing and the power consumption for your design.

### ***Netlist Viewer***

The Netlist Viewer displays your netlist in a hierarchical manner (though only if you import a hierarchical, or non-flattened, netlist), providing you with a logical view of your design. The Netlist Viewer can be used alone to explore each level of the hierarchy and to trace signals. Used with PinEdit, ChipEdit, or Timer, the Netlist Viewer assists you in meeting area and timing goals by helping you with critical path identification.

**Axcelerator Only:** When you use the Netlist Viewer with Axcelerator devices, you can choose to display the Pre-Optimized Netlist or Optimized Netlist using the View menu.

### ***PinEdit***

PinEdit is a graphical interface that allows designers to view pin locations and manually assign, edit, and fix pin locations for a design. Manual pin assignment is optional. PinEdit should be used to fix pins that are automatically assigned by Designer to maintain pin locations once a design is ready to be used to program a device. PinEdit is also used to customize I/O attributes and assign I/O bank standards (for Axcelerate devices). Refer to the *PinEdit User's Guide* for additional information.

### ***ChipEdit***

ChipEdit (ChipViewer for flash devices) is a graphical interface that allows designers to view a design's macro placement and to edit the placement of both I/O and logic macros. ChipEdit also enables you to see the nets between selected macros. Refer to the *ChipEdit User's Guide* for additional information.

### **Timer**

Timer is an optional interactive tool used for timing verification and for entering timing constraints. Timing information can be displayed in a tabular or graphical format. A report generator is also provided. Refer to the *Timer User's Guide* for additional information.

### **SmartPower (Axcelerator, ProASIC, and ProASIC<sup>PLUS</sup> only)**

SmartPower is Actel's state of the art power analysis tool. Power analysis is a convenient and thorough method of analyzing, debugging and validating the power performance of a design. This is achieved by breaking the design down into a nets, blocks, and gates, and then calculating the power requirements of the component parts. SmartPower includes a report generator that summarizes your power consumption information. Please refer to the *SmartPower User's Guide* for more information.

### **Back-Annotate**

Back-Annotate lets you generate a post-layout timing file (\*.sdf) and a netlist file. For Axcelerator, Back-Annotate generates a post-compile optimized netlist.

## **ACTgen Macro Builder**

ACTgen is a graphical macro generation tool that creates optimized logic elements that can be easily included in your schematic or synthesis design. Architecture-specific rules control the generation of macros, so the quality of output is "correct by construction," and no logic verification is required. Refer to "Generating Macros Using ACTgen" in *A Guide to ACTgen Macros* for additional information.

## **Silicon Expert**

Silicon Expert can be used during design creation to add I/Os to a design, balance buffer trees, or generate a netlist report. Silicon Expert can also be used after design creation to translate a structural netlist from one format to another. Refer to the *Silicon Expert User's Guide* for additional information. Not available for ProASIC, ProASIC<sup>PLUS</sup>, and Axcelerator devices.

## *Designer Maintenance*

After your first installation of the Designer, unless you completely remove the original installation, Setup always proceeds directly into maintenance mode.

Maintenance mode (also accessible from the Designer main menu, in the Programs menu, under the Start menu) enables the following three options:

Modify: Select new program components to add or select currently installed components to remove.

Repair: Reinstall all program components installed by the previous setup.

Remove: Remove all installed components.

## *Schematic-Based Design Methodology*

If you prefer designing with schematic tools, Actel offers a complete tool suite that lets you take your designs from concept to silicon. On the front end, ACTgen integrates with third-party CAE tools for schematic-entry and gate-level simulation. Once your design has been created and verified, Designer completes the design with place-and-route, timing analysis, and back annotation for timing verification. Refer to “Schematic-Based Design Flow Illustrated” on page 17 for an overview of the Designer Series schematic-based design flow.

## *HDL Synthesis-Based Design Methodology*

If you prefer a high-level design methodology, the Designer Series allows you to move from design description to a programmed part. To get you through the design phase, Actel supports Verilog and VHDL synthesis tools, as well as behavioral simulation. Once the design is synthesized, Silicon Expert and Designer help you complete the design with place-and-route, timing analysis, and timing verification.





# Actel Design Flows

The Designer Series integrates with third party schematic and HDL CAE tools to implement, simulate, and program Actel devices. This chapter illustrates and describes the design flows for creating Actel designs using the Designer Series and third-party CAE software.

## Schematic-Based Design Flow Illustrated

Figure 2-1 shows the schematic-based design flow for an Actel device using Designer Series and third-party schematic capture software.<sup>1</sup>

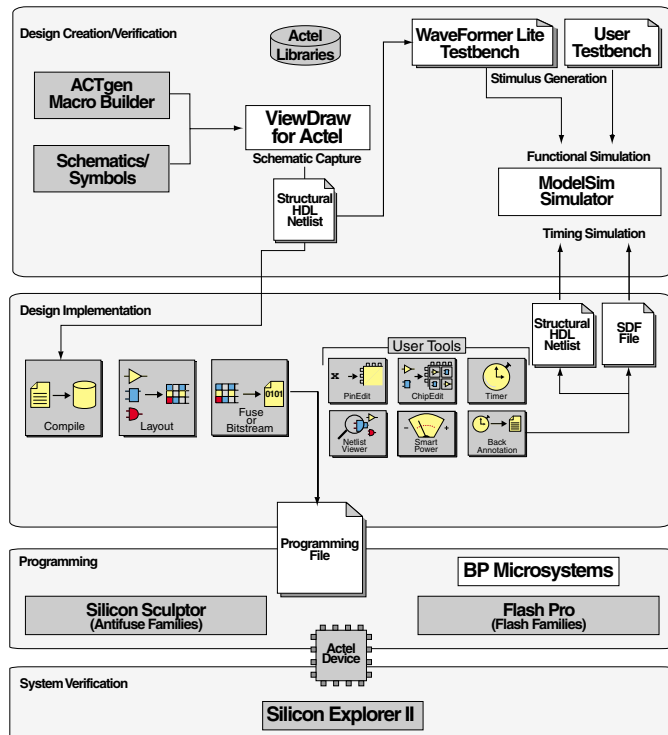

Figure 2-1. Actel Schematic-Based Design Flow

1. Actel-specific utilities/tools are denoted by the grey boxes in Figure 2-1. Also, ChipEdit is replaced by ChipView for the ProASIC and ProASIC<sup>PLUS</sup> families.

## Schematic-Based Design Flow Overview

The Actel schematic-based design flow has four main steps; design creation/verification, design implementation, programming, and system verification. These steps are described in the following sections.

Third-party software users can also refer to the Actel *Cadence Interface Guide*, *Mentor Graphics Interface Guide*, *Innoveda eProduct Designer Interface Guide* for information about using these tools with Actel software and devices.

### **Design Creation/ Verification**

During design creation/verification, a schematic representation of a design is captured using third-party schematic capture software (such as the Libero Series FPGA Design Suite, available from Actel<sup>1</sup>). After design capture, a pre-layout (functional) simulation can be performed with third-party simulation software. Finally, an EDIF netlist is generated for use in Designer.

#### **Schematic Capture**

Enter your schematic using a third-party schematic capture tool, such as Libero. Refer to the additional documentation included with your schematic capture tool for information.

#### **Functional Simulation**

Perform a functional simulation of your design using a third-party simulation tool (Libero) before generating an EDIF netlist for place-and-route. Functional simulation verifies that the logic of the design is correct. Unit delays are used for all gates during functional simulation. Refer to the Actel Interface Guides and the documentation included with your simulation tool for information about performing functional simulation.

#### **Netlist Generation**

After you have captured and verified your design, you may place-and-route in Designer. You may place-and-route with an EDIF, Verilog, or VHDL netlist. Refer to your the manuals included in your simulation

---

1. Visit our website at <http://www.actel.com/products/tools/index.html> for more information on the Libero Series FPGA Design Suite.

software for more information on creating an EDIF, Verilog, or VHDL netlist.

## ***Design Implementation***

During design implementation, a design is placed-and-routed using Designer. Additionally, static timing analysis can be performed in Designer with the Timer tool. After place-and-route, post-layout (timing) simulation is performed using third-party simulation software.

### ***Place-and-Route***

Use Designer to place-and-route your design. Refer to the *Designer User's Guide* for more information.

### ***Static Timing Analysis***

Use the Timer tool in Designer to perform static timing analysis on your design. Refer to the *Timer User's Guide* for more information.

You can also perform static timing analysis using third-party software. Refer to the documentation included with your static timing analysis tool for information.

### ***Power Analysis (Optional)***

**Axcelerator, ProASIC, and ProASIC<sup>PLUS</sup> Only:** The SmartPower tool is a state of the art power estimation tool. Enter your clock and data frequencies and use SmartPower to estimate both the static and dynamic power of your design, and to identify your most power-hungry blocks, nets, and gates. The tool accepts switching activity from simulation in VCD (value change dump) and SAIF (switching activities interface and probabilities file) formats.

### ***Timing Simulation***

Perform a timing simulation of your design using a third-party simulation tool after placing and routing it in Designer. Timing simulation requires that data be extracted and back annotated from Designer. Refer to the Actel Interface Guides and the documentation included with simulation tool for information about performing timing simulation.

## ***Programming***

Program a device with programming software and hardware from Actel or a supported third-party programming system. Refer to the *Designer User's Guide*

and the *Activator and APS Programming System Installation and User's Guide* or *Silicon Sculptor User's Guide* for more information.

## **System Verification**

You can perform system verification on a programmed device using the Actel Silicon Explorer diagnostic tool. Refer to the *Silicon Explorer Quick Start* for more information.

## HDL Synthesis-Based Design Flow Illustrated

Figure 2-2 shows the HDL synthesis based design flow for an Actel device using Designer Series and third-party HDL synthesis software.<sup>1</sup>

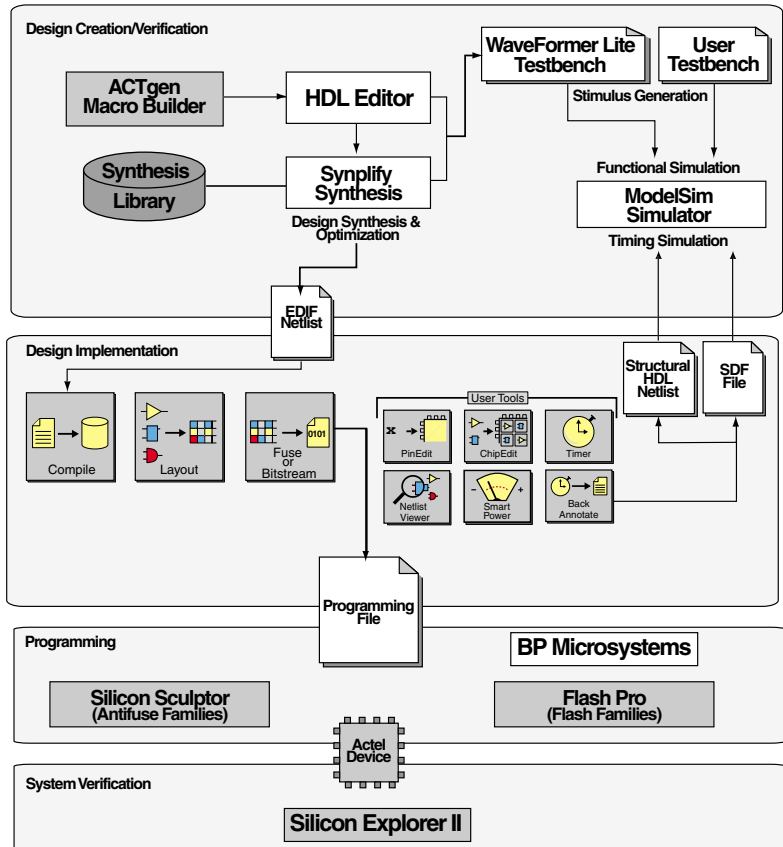

Figure 2-2. Actel HDL-Based Design Flow

1. Actel-specific utilities/tools are denoted by the grey boxes in Figure 2-2.

## HDL Synthesis-Based Design Flow Overview

The Actel HDL synthesis-based design flow has four main steps: design creation/verification, design implementation, programming, and system verification. These steps are described in the following sections.

Third-party software users can also refer to the Actel *Cadence Interface Guide*, *Mentor Graphics Interface Guide*, *Synopsys Synthesis Methodology Guide*, *VHDL Vital Simulation Guide*, *Verilog Simulation Guide*, and the *Innoveda eProduct Designer Interface Guide* for information about using these tools with Actel software and devices.

### **Design Creation/ Verification**

During design creation/verification, a design is captured in an RTL-level (behavioral) HDL source file. After capturing the design, behavioral simulation of the HDL file can be performed with third-party simulation software to verify that the HDL code is correct. The code is then synthesized into a structural HDL netlist. After synthesis, structural simulation of the design can be performed. Finally, an EDIF netlist is generated for use in Designer and configured with the structural netlist for back annotation simulation with third-party simulation software.

#### **HDL Design Source Entry**

Enter your design source using a text editor or a context-sensitive HDL editor. Your HDL design source can contain RTL-level constructs as well as instantiations of structural elements, such as ACTgen macros. Refer to the *Actel HDL Coding Style Guide*, or the *Synopsys Synthesis Methodology Guide* for additional information about writing HDL code for Actel designs.

#### **Functional Simulation**

Perform a functional simulation of your design before synthesis. Functional simulation verifies the functionality of your HDL code. Typically, unit delays are used and a standard HDL test bench can be used to drive simulation. Refer to the Actel Interface Guides, the Actel Simulation Guides, and the documentation included with your simulation tool for information performing Functional simulation.

### ***Synthesis***

After you have created your functional HDL source file, you must synthesize it using a third-party synthesis tool before placing and routing it in Designer. Synthesis transforms the behavioral HDL file into a gate-level netlist and optimizes the design for a target technology. Refer to the documentation included with your synthesis tool for information about performing design synthesis.

### ***Netlist Generation***

After you have created, synthesized, and verified your design, you can place-and-route in Designer using an EDIF, Verilog, or VHDL netlist. This netlist is also used to generate a structural HDL netlist. Refer to the documentation included with your synthesis tool for information about generating an EDIF, Verilog, or VHDL netlist.

### ***Structural HDL Netlist Generation***

Generate a structural HDL netlist from your EDIF/Verilog/VHDL netlist for use in structural and timing simulation by either exporting it from Designer, translating it using Silicon Expert. Refer to the documentation included with your synthesis tool for information about generating a structural netlist.

### ***Structural Simulation***

Perform a structural simulation with a third-party simulation tool before placing and routing it. Structural simulation verifies the functionality of your post-synthesis structural HDL netlist. Unit delays included in the compiled Actel libraries are used for every gate. Refer to the Actel Interface Guides, the Actel Simulation Guides, and the documentation included with your simulation tool for information about performing structural simulation.

## ***Design Implementation***

Design Implementation for synthesis based designs is identical to that of the schematic based designs. Refer to “Design Implementation” on page 19 for more information.





---

## Design Considerations

This chapter contains information and procedures to assist you in creating Actel designs. For more information on creating designs for ProASIC devices, please refer to “ProASIC Design Considerations” on page 57.

### Naming Conventions

This section lists schematic, Verilog, and VHDL naming conventions that should be followed to avoid potential design flow problems.

#### Schematic

Use only alphanumeric and underscore “\_” characters for schematic net and instance names. Do not use asterisks, forward slashes, backward slashes, or spaces. Refer to the *ViewDraw User's Guide* for more information on schematic naming conventions.

#### VHDL

If simulation is to be completed using a VHDL simulator, it is important to create schematics or write HDL code that complies with the VHDL naming conventions. The following naming conventions apply to VHDL designs:

- VHDL is not case sensitive.
- Two dashes “--” are used to begin comment lines.
- Names can use alphanumeric characters and the underscore “\_” character.
- Names must begin with an alphabetic letter.
- Do not use two underscores in a row, or use an underscore as the last character in the name.
- Spaces are not allowed within names.
- Object names must be unique. For example, you cannot have a signal named A and a bus named A(7 downto 0).

### **VHDL Keywords**

The following is a list of the VHDL reserved keywords:

abs	downto	library	postponed	subtype
access	else	linkage	procedure	then
after	elsif	literal	process	to
alias	end	loop	pure	transport
all	entity	map	range	type
and	exit	mod	record	unaffected
architecture	file	nand	register	units
array	for	new	reject	until
assert	function	next	rem	use
attribute	generate	nor	report	variable
begin	generic	not	return	wait
block	group	null	rol	when
body	guarded	of	ror	while
buffer	if	on	select	with
bus	impure	open	severity	xnor
case	in	or	shared	xor
component	inertial	others	signal	
configuration	inout	out	sla	
constant	is	package	sra	
disconnect	label	port	srl	

## **Verilog**

If simulation is to be completed using a Verilog simulator, it is important to create schematics or write HDL code that complies with the Verilog naming conventions. The following naming conventions apply to Verilog HDL designs:

- Verilog is case sensitive.
- Two slashes “//” are used to begin single line comments. A slash and asterisk “/\*” are used to begin a multiple line comment and an asterisk and slash “\*/” are used to end a multiple line comment.
- Names can use alphanumeric characters, the underscore “\_” character, and the dollar “\$” character.
- Names must begin with an alphabetic letter or the underscore.
- Spaces are not allowed within names.

### Verilog Keywords

The following is a list of Verilog reserved keywords:

always	endfunction	macromodule	realtime	tran
and	endmodule	medium	reg	tranif0
assign	endprimitive	module	release	tranif1
attribute	endspecify	nand	repeat	tri
begin	endtable	negedge	rnmos	tri0
buf	endtask	nmos	rpmos	tri1
bufif0	event	nor	rtran	triand
bufif1	for	not	rtranif0	trior
case	force	notif0	rtranif1	trireg
casex	forever	notif1	scalared	unsigned
casez	fork	or	signed	vectored
cmos	function	output	small	wait
const	highz0	parameter	specify	wand
deassign	highz1	pmos	specparam	weak0
default	if	posedge	strength	weak1
defparam	ifnone	primitive	strong0	while
disable	initial	pull0	strong1	wire
edge	inout	pull1	supply0	wor
else	input	pulldown	supply1	xnor
end	integer	pullup	table	xor
endattribute	join	remos	task	
endcase	large	real	time	

## Hierarchical Designs

Multiple-level or hierarchical designs are created by creating symbolic representations of blocks and adding them to other levels. The Designer software reads and writes hierarchical netlists.

## Multiple Sheet Designs

The Designer software supports multiple sheet designs. Each sheet in the design is considered as part of a schematic, and it is not considered as a level of hierarchy. Most schematic capture tools have page connectors to connect the sheets. Refer to the documentation provided with your schematic capture tool for additional information.

## Actel Libraries

Actel provides libraries to support schematic- and synthesis-based designs. Logic can be described in behavioral languages (VHDL or Verilog). Structured logic such as counters, adders, and comparators can be automatically built using the ACTgen Macro Builder. Functions can be exclusively behavioral, schematic, or a combination of the two. Timing definition is supported by the timing driven layout tools. I/O definitions can be described in the design source or in Designer.

## Adding Power and Ground

Actel provides special VCC and GND macros to connect nets to power and ground. Add the VCC and GND macros to your design and connect them by nets to the functional logic making up the design. It is important to use the symbols provided by Actel in order to prevent design flow issues. Do not add power and ground to designs by naming nets or adding third-party power and ground symbols. Refer to the Actel Interface Guides or the *Libero User's Guide* for information about adding power and ground to your design.

## *Adding a Global Network*

The Actel architecture provides global networks that allow high fanout drive for flip-flops and latches with minimal skew. The available global networks are shown in Table 3-1.

Table 3-1. Global Network Attributes

Input Pad Name	Type	Family	#	Internal Drive Option	Macro	Note
CLK	routed	ACT 1 40MX	1	Yes (CLKBIBUF only)	CLKBUF; CLKBIBUF	Can adjust skew with clock balancing
CLKA CLKB	routed	ACT 2; 1200XL; ACT 3; 3200DX; 42MX; 54SX; 54SX-A; eX	2	Yes <sup>a</sup>	CLKBIBUF; CLKBIBUF <sup>b</sup> ; CLKBUF; CLKINT; CLKBUF <sup>b</sup> ; CLKINT <sup>b</sup>	Can connect to CLK and G (gate) pins
CLKA CLKB CLKC CLKD	routed	Axcelerator	4	yes	CLKBUF; CLKINT	Can connect to CLK and G (gate) pins
HCLK	dedicated	ACT 3; 54SX; 54SX-A; eX	1	No	HCLKBUF	Directly hard-wired to cer- tain S-modules <sup>c</sup>
HCLKA HCLKB HCLKC HCLKD	dedicated	Axcelerator	4	No	HCLKBUF; HCLKINT	Directly hard-wired to cer- tain S-modules <sup>c</sup>
IOCLK	dedicated	ACT 3	1	No	IOCLKBUF	Connected to all I/O module registers
IOPCL	special	ACT 3	1	No	IOPCLBUF	Connected to I/O module set and reset pins
QCLK A-D	routed	3200DX <sup>d</sup> ; 42MX; 54SX72A	4	Yes	QCLKBUF ; QCLKBUF <sup>b</sup> ; QCLKBIBUF <sup>b</sup> ; QCLK- BIBUF <sup>b</sup> ; QCLKINT; QCLKINT <sup>b</sup>	Each QCLK drives a quad- rant of the device

a. The Internal Drive Option for ACT 2, 1200XL, ACT 3, 3200DX, 42MX, 54SX and 54SX-A can only be utilized by selecting the CLKINT macro to drive an internal clock network.

b. 54SX72A only.

c. HCLK is hardwired to all S-modules. Only the sequential macros made of C-modules cannot be driven by HCLK.

d. Not available in 32140DX, 3265DX

## **Routed Clocks**

Routed clocks are clock networks with unlimited fanout and offer clock speeds independent of the number of logic modules being driven. Routed clocks can be used as RESET and PRESET networks to drive the reset and preset pins of internal logic modules. They can also be connected to most logic module inputs.

### **CLK, CLKA, CLKB**

CLK, CLKA, CLKB, CLKC<sup>1</sup>, and CLKD<sup>1</sup> are routed global clocks that can be used by selecting the CLKBUF, CLKBIBUF, CLKBIBUFI, CLKINT, or CLKINTI macro.

### **QCLK**

QCLK (available on 42MX, 24MX36, 42MX36, 3200DX, and 54SX72A devices) is a routed quadrant or global clock that can drive from one to four quadrants on a device. In addition to global RESET and PRESET networks, QCLK can be used as a quadrant RESET and PRESET network. QCLK can be used by selecting the QCLK, QCLKINT, QCLKINTI, QCLBUF, QCLBUFI, QCLBIBUF, QCLBIBUFI macro.

**Note:** QCLK is not available for Axcelerator.

## **Dedicated Clocks**

Dedicated clocks are clock networks that are directly wired to either sequential or I/O modules. They contain no programming elements in the path from the I/O pad driver to the input of sequential or I/O modules. These clocks provide sub-nanosecond skew and guaranteed performance.

### **HCLK**

HCLK (HCLKA, HCLKB, HCLKC, and HCLKD for Axcelerator devices) is a dedicated hard-wired clock input for sequential modules. HCLK is directly wired to each sequential module and offers clock speeds independent of the number of sequential modules being driven. HCLK can be used by selecting the HCLKBUF macro. Table 3-2 lists the ACT 3 sequential elements and Table 3-3 lists the 54SX/54SX-A/eX sequential elements that cannot be connected to HCKLBUF because they are built from combinatorial modules:

---

1. Axcelerator only.



*Table 3-2. ACT 3 Sequential Elements that Cannot Connect to HCKLBUF*

DFP1	DFP1B	DFP1D	DFPCA	DFPC	DLC1
DLC1A	DLC1F	DLC1G	DLE2C	DLE3B	DLE3C
DLP2C	DLP1A	DLP1B	DLP1C	DFP1A	

*Table 3-3. 54SX/54SX-A/eX Sequential Elements that Cannot Connect to HCKLBUF*

DLC1	DLC1A	DLC1F	DLC1G	DLE2C	DLE3B
DLE3C	DLP2C	DLP1A	DLP1B	DLP1C	DFP1A

**IOCLK**

IOCLK is a dedicated hard-wired clock input for I/O modules. IOCLK is directly wired to each I/O module register and offers speeds independent of the number of I/O modules being driven. IOCLK can be used by selecting the IOCLKBUF macro.

**Special Clocks**

Special clocks are special hard-wired networks for I/O modules that can only drive preset/clear pins of I/O modules. IOPCL, the only special clock, is a special network directly wired to the preset and clear inputs of all I/O registers. IOPCL functions as an I/O when no I/O preset or clear macros are used. IOPCL can be used by selecting the IOPCLBUF macro.

**PLL**

PLLs (Phase-Locked Loops) are dedicated clock resources that are available for the ProASIC Plus (two PLLs) and Axcelerator families. Each Axcelerator device has eight PLLs; four PLLs may be used on the HCLK network and four PLLs may be used on the routed clock network.

Use PLLs to reduce the skew on the clock network. PLLs can accept feedback from internal and external clock sources, and used to

multiply, divide, and phase-shift clocks internally. You can also cascade your PLLs to obtain a specific clock frequency.

## Using ProASIC Global Routing Resources

Use the automatic global resource assignments specified by Designer. Each ProASIC device includes four dedicated global lines that all tiles in the device can access. These lines exhibit very low skew. When Designer imports the netlist and device data, it can automatically assign unused global resources to the nets with the highest fanouts (for example, clock and reset signals).

If high fanout signals mapped by Designer to global resources are buffered, Designer automatically removes these buffers. ProASIC devices provide automatic buffering for global resources.

Signals can also be assigned to the global resources by using Designer global primitives in netlists, and by specifying constraint files for Designer.

The checker contains a description of the highest fanout nets in a design and the results of automatic global assignments. If your constraints appear not to have been honored, refer to this report file.

## Combinability

The functionality of some combinations of gates and flip-flops can be combined to fit into a single logic module instead of a logic module to implement each gate or flip-flop. This ability is called combinability. Designer has an automatic utility called the Combiner to perform this function, as well as to reduce the logic in other ways.

The Combiner reduces the number of logic modules, logic levels, and fan-ins in a design by remapping, removing, and combining certain hard macros, including the deletion of buffers on clock networks. It also simplifies a design netlist using features of the Actel architecture.

The Combiner is integrated into the Compile function in Designer. It improves the density, speed, and routability of a design by performing the following functions, which are described in the following sections:

- Combinatorial Module Reduction
- Sequential Remapping
- Unused Logic Removal
- Constant Input Reduction
- Fan-in Reduction
- I/O-Register Combining in Axcelerator
- I/O-FIFO Combining in Axcelerator

## **Combinatorial Module Reduction**

Combinatorial Module Reduction reduces the number of combinatorial modules and logic levels, giving a design more density and speed. It does this in one of the following two ways:

1. It combines two or more combinatorial macros into a single macro. For example, two 2-input AND gates, two inverters, and three inverters are combined into a single 3-input AND gate, a buffer, and an inverter respectively, shown in Figure 3-1.

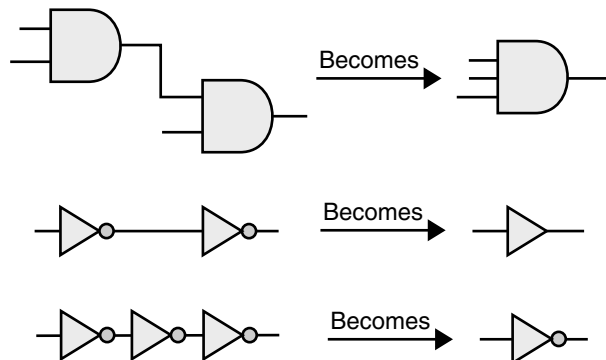

*Figure 3-1. Combined Combinatorial Macros*

2. It combines a combinatorial macro and a sequential macro into a single sequential macro. For example, a combinatorial macro “MUX” and a sequential macro “DF1” are combined into a single sequential macro “DFM,” shown in Figure 3-2. Combinatorial Module Reduction is not available for ACT 1 or 40MX devices because these

families do not have sequential modules. Module Reduction is not available for 54SX/54SX-A or eX devices. Instead, an automatic DirectConnect between a combinatorial module and a sequential module is used.

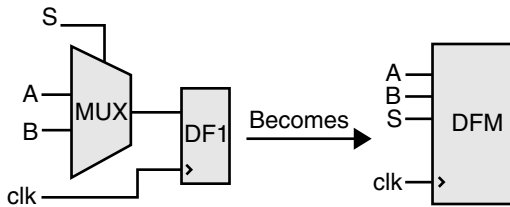

Figure 3-2. Combined Combinatorial and Sequential Macros

## Sequential Remapping

Sequential Remapping attempts to achieve better results in the density, speed and routability of a design. If Sequential Remapping cannot reduce the total number of combinatorial macros in the design, the Combiner does not use it. Sequential Remapping is not available for ACT 1 or 40MX devices because these families do not have sequential modules. Sequential Remapping is not available for 54SX/54SX-A or eX devices because the sequential modules in 54SX/54SX-A and eX do not have a combinatorial component. Instead, optimal performance is achieved by an automatic DirectConnect between a combinatorial module and a sequential module whenever possible. Sequential Remapping performs the following three steps in order:

1. It divides complex sequential library macros into basic combinatorial and sequential macros. For example, a D-type flip-flop with 2-input multiplexed data “DFM” remaps into a 2 to 1 multiplexer “MX2” and a D-type flip-flop “DF1.” The total number of logic modules has temporarily increased from one combinatorial and one sequential module to two combinatorial and one

sequential module, shown in Figure 3-3.

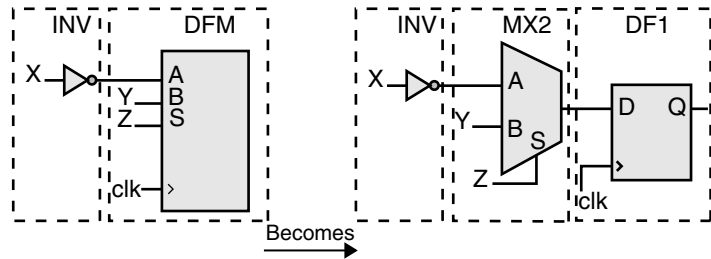

Figure 3-3. Complex Macros Divided

2. It implements the new combinational macro by combining the basic combinational macro from step 1 with its previous combinational macro in a design. For example, “MX2” and an inverter “INV” are combined into “MX2A.” The total number of logic modules is decreased to one combinational and one sequential module, shown in Figure 3-4.

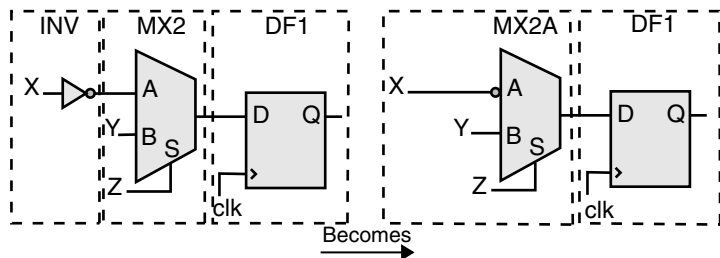

Figure 3-4. Logic Modules Decreased

3. It combines the new combinational macro from step 2 with the basic sequential macro from step 1. For example, “MX2A” and “DF1” are combined into a D type flip-flop with 4 input multiplexed data, active low clear, and active high clock “DFM6A.” The total number

of logic modules is further decreased to one sequential module, shown in Figure 3-5.

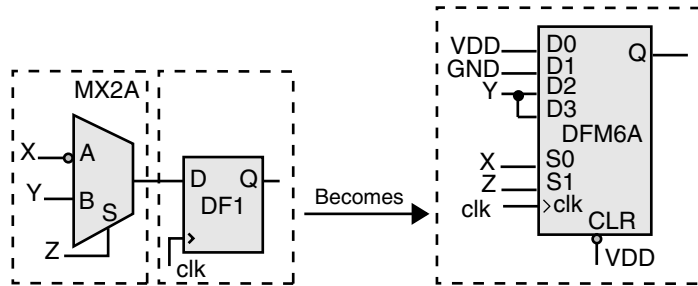

Figure 3-5. Logic Reduced to One Sequential Module

### Unused Logic Removal

Unused Logic Removal removes all logic macros that are not driving any other logic macro input or do not propagate to an output pad. The removal of such macros does not affect the functionality of the circuit. An example of Unused Logic Removal is shown in Figure 3-6.

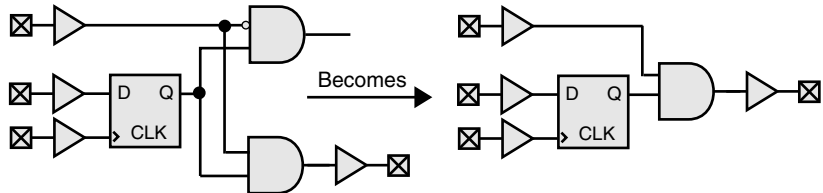
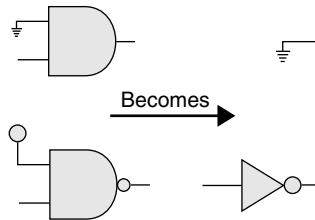

Figure 3-6. Unused Logic Removal

### Constant Input Reduction

Every Actel hard macro can be mapped or configured in many different ways to implement logic functions. However, when macro inputs are tied to power or ground, the number of configurations available to the place-and-route software is decreased. Constant Input Reduction reconfigures macros that have unused inputs connected to power or ground into logically equivalent functions with the power or ground connections eliminated. Constant Input Reduction only reconfigures combinatorial macros. Sequential macros that have inputs

connected to power or ground are not affected. Figure 3-7 illustrates how Constant Input Reduction is achieved.



*Figure 3-7. Constant Input Reduction*

### **Fan-in Reduction**

Fan-in Reduction reduces the number of inputs of a combinatorial macro that has inputs tied together by mapping it to a logically equivalent macro with fewer inputs. This function substantially improves the routability of a design. Fan-in Reduction does not reduce the number of logic modules and only reconfigures combinatorial macros. Sequential macros that have inputs tied together are not affected. Figure 3-8 illustrates how Fan-in Reduction is done.

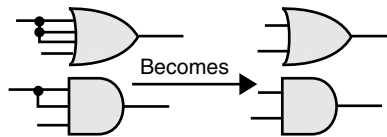

*Figure 3-8. Fan-in Reduction*

### **Back Annotation Effects**

The Combiner does not change the functionality of a design. Rather, it improves the density, speed and routability of a design. Changes resulting from logic removal or combining are not visually back annotated to the schematic, but the timing is adjusted accordingly. The removal or combining of logic does not adversely affect either back annotation to a simulator or timing analysis performed by Timer.

There are slight differences in the way delays are back annotated to a simulator and how they are viewed in Timer. Figure 3-9 shows how delays are viewed in schematics before combining.

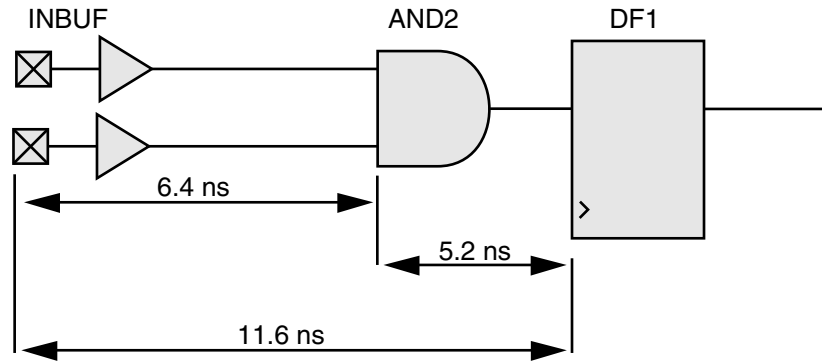

Figure 3-9. Delays Before Combining

A delay of 11.6ns (=6.4+5.2) represents the macro delay of “INBUF” and the wire delay between “INBUF” and “AND2” (6.4ns) plus the macro delay of “AND2” and the wire delay between “AND2” and “DF1” (5.2ns).

When “AND2” is combined with “DF1,” the macro delay of “AND2” and the wire delay between “AND2” and “DF1” (5.2ns) no longer exists. However, “AND2” still exists on the schematic. Therefore, for back annotation purposes, Designer back annotates a delay of 0.0ns for the macro delay of “AND2” and the wire delay between “AND2” and “DF1.” Timer also shows a 0.0ns delay for the macro delay of “AND2” and the wire delay between “AND2” and “DF1.” The resulting delay is 6.4ns (=6.4+0.0) instead of 11.6ns (=6.4+5.2) because of the zero delay for the macro delay of “AND2” and the wire delay between “AND2” to “DF1.” Figure 3-10 illustrates this process.



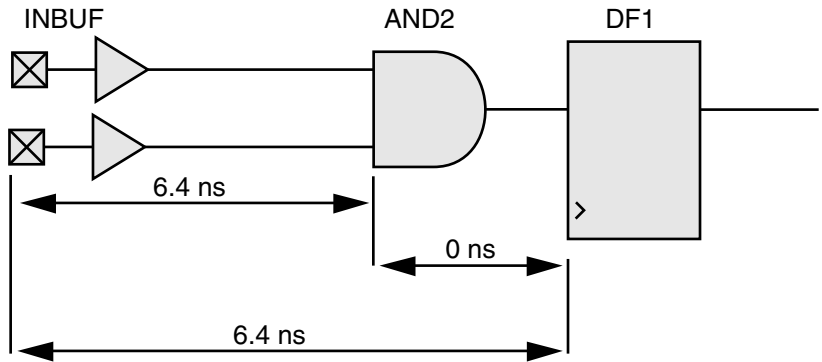

Figure 3-10. Delays After Combining

### Combinability with ACT 1 and 40MX Devices

The ACT 1 and 40MX architectures do not use sequential modules to implement flip-flops and latches. Therefore, combinatorial macros with flip-flops and latches cannot be combined. However, DFM type flip-flops with their inputs tied to GND and/or VCC can be used to implement a logic function with fewer modules and shorter propagation delay. Figure 3-11 illustrates how to tie the “A,” “B,” and “Select” inputs to implement a given gate/flip-flop combination in ACT 1 or 40MX using one “DFM.” This lowers the module count and the propagation delay.

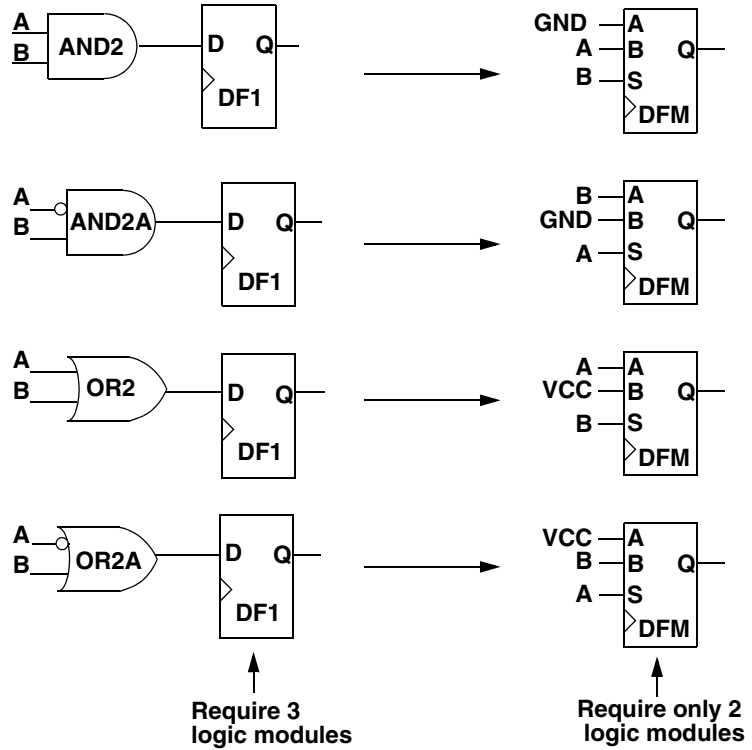

Figure 3-11. DFM Ties-Offs to Reduce Logic Module Count

## Net Loading

High fanout degrades performance and increases the potential of unrouted nets. Due to physical limitations, Designer does not permit fanouts greater than 24 (except for the Axcelerator family - the fanout limit for Axcelerator devices is 32; check <http://www.actel.com/guru> for device specific information). In addition, the software warns you if any nets have an excess of 10 loads. If these nets are not speed-critical and there are a modest number of them, you can ignore these warnings. However, if critical nets in the design have a fanout greater than 10, you should modify them by buffering, as shown in Figure 3-12.

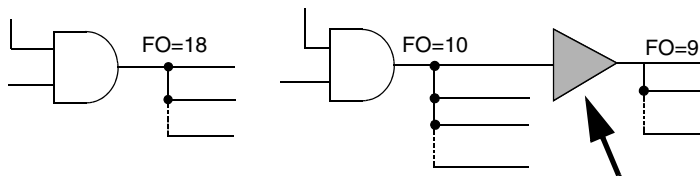

Figure 3-12. Buffering

An alternative method to buffering is duplicating logic to eliminate the buffer delay, shown in Figure 3-13.

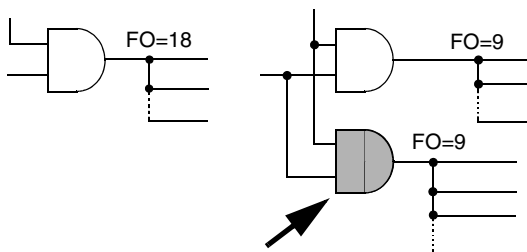

Figure 3-13. Duplicating Logic

Both buffering and duplicating logic cost additional logic modules. You can use buffering if you do not care about the skew or if you want to minimize the amount of logic resources used, because buffering generally takes less logic than logic duplication. However, Actel recommends that you duplicate logic to reduce fanout because it does not add an additional delay in the form of a buffer and it reduces skew. Silicon Expert is capable of duplicating logic automatically; refer to the *Silicon Expert User's Guide* for more information.

## Logic and I/O Utilization

The Designer software calculates the logic module and I/O module utilization. You can view module utilization by generating a Status report.

To improve the chances of optimal routing, Actel recommends that the total logic module utilization be between 50% and 85%.

- Lower utilization, especially with high I/O usage, causes excessively long delays and, possibly, unrouted nets.
- High utilization should be avoided if there is significant use of high pin count macros (for example, “MX4” and “DFM6A”).

If the design requires additional resources, you can use a larger device by changing the device and package selection within Designer. The specialized I/O macros take advantage of architectural enhancements with the later families. Use these macros to improve performance.

Refer to the Actel *FPGA Data Book and Design Guide* and *Macro Library Guide* for additional information. Also, refer to Actel’s Guru website at <http://www.actel.com/guru> for more information on routability.

## Adding Properties

This section describes how to add properties to your designs.

**Note:** ALSPIN and ALSPRESERVE are not available for ProASIC devices.

### **ALSPRESERVE**

When Designer compiles a design, one of the functions of the Combiner is to combine (optimize) combinatorial functions into sequential macros whenever possible. Combining logic does not affect the functionality of the circuit. To prevent such combining, an “ALSPRESERVE” property may be added to the net connecting the macros that would otherwise be combined, as shown in Figure 3-14. The “ALSPRESERVE” property does not need to have a value assigned to it. Most schematic capture tools pass the property to the netlist. Refer to the

documentation provided with your schematic capture tools for information about adding properties to nets.

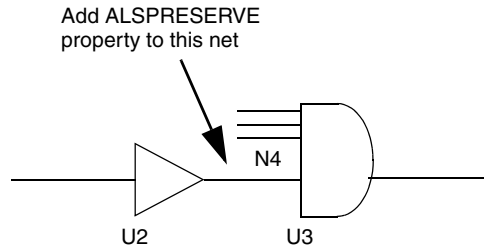

Figure 3-14. Adding ALSPRESERVE Property to a Net

Example EDIF netlist:

```
(net N4 (joined (portRef Y (instanceRef U2))
               (portRef D (instanceRef U3)))
  (property ALSPRESERVE (boolean (true))))
```

## BUFD and INVD Delay Macros

The suggested uses of BUFD and INVD are as follows:

- Maintain the phase relationship between clock and data input signals when sending signals derived from them these signals off-chip. This application enables them to meet external setup and hold requirements.
- Maintain the phase relationship of clock and data input signals in designs with high-fanout clock signals.

### Maintaining Phase Relationships

As shown in Figure 3-15, a certain phase relationship exists between the clock and data signals (generally, the data signal lags the clock signal). Employing BUFD is recommended to maintain this phase relationship. All Actel antifuse device families have a restriction that a CLKBUF cannot be connected directly to an OUTBUF, so Designer software will automatically insert a BUFF module (inst3 in Figure 3-15). This will introduce a delay that may cause the data signal to arrive ahead of the sys\_clk signal going off-chip. To prevent this, the user can insert a BUFD macro in his netlist. The BUFD, unlike a regular BUFF, is

assigned the ALSPRESERVE property. This ensures that the BUFD will not be optimized away during the compilation step and hence can offset the delay caused by automatic insertion of the BUFF in the sys\_clk path. This technique maintains the phase relationship of the data and clock inputs when going off-chip and the external setup and hold requirements can be met.

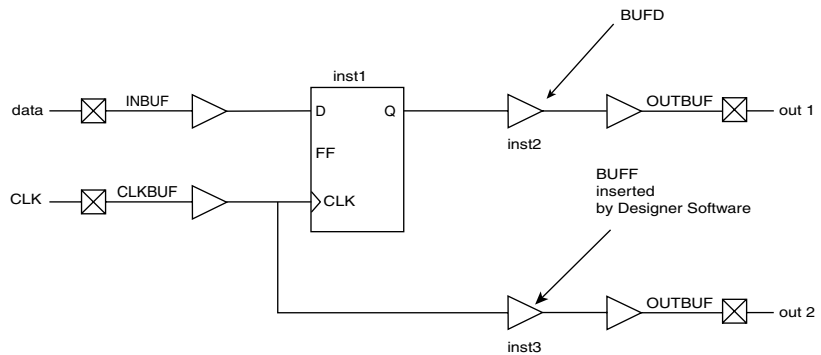
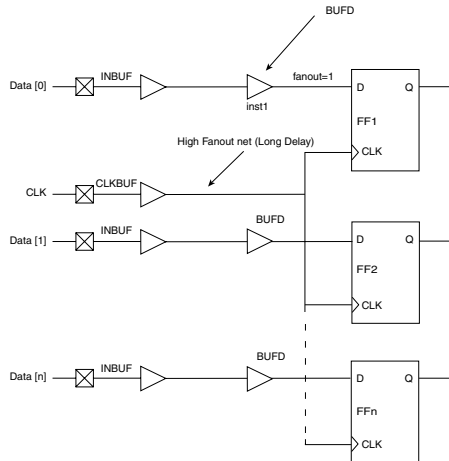

Figure 3-15. Phase Relationship Control - Data and System Clock using BUFD

In Figure 3-16, the clock signal coming from the CLKBUF has a high fanout. This means increased capacitive loading and hence increased delay. In contrast, the data signal has a fanout of only one. The clock network's high fanout may allow the data input to (undesirably) lead the clock signal. Again, introducing one or more BUFD macros (inst1) in the data signal path provides enough delay to offset the delay of the high-fanout clock net.

If inversion of the signal is required in addition to delay, the INVD macro is available. Again, the ALSPRESERVE property is assigned to this macro to avoid elimination during optimization steps.



*Figure 3-16. Phase Relationship Control - Designs with High Clock Fanouts*

### Usage Model - HDL Design Flow

None of the synthesis tools that support Actel technologies will infer the INVD or BUFD macros in the synthesized netlist. Simulation library models of INVD and BUFD, similar to their INV and BUFF counterparts, are available from Actel in both VHDL and Verilog. The manual process for buffer insertion is as follows:

1. Import the synthesized netlist into Designer. Run compile and layout.
2. Invoke Timer from Designer to check the timing/phase relationships for the signals of interest.
3. Using a text editor, manually modify the netlist and insert BUFD and/or INVD macros into the desired paths.
4. Import the modified netlist into Designer. Again run compile and layout.

5. Invoke Timer again to review the delays for the signals of step 2. If necessary, repeat steps 3 through 5 until the design timing requirements are met.

### ***Usage Models - Schematic Capture Design Flow***

INVDs and BUFDs are available for the following Actel-supported schematic capture tools:

- ConceptHDL PE13.5 and PE13.6
- Mentor Graphics c.4 and D.1
- ePD 1.1/2.0

To avoid inadvertent instantiation of INVD or BUFD where INV or BUFF is intended, the graphical symbols for INVD and BUFD have warning labels "Special Use Only."

The flow for buffer insertion is as follows:

1. Generate an EDIF netlist with the schematic tool.
2. Import the EDIF netlist into Designer. Run compile and layout.
3. Invoke Timer from Designer to check the timing/phase relationships for the signals of interest.
4. Edit the schematics to insert BUFD and/or INVD macros into the desired paths.
5. Check and save your schematics. Generate an EDIF netlist from the modified schematics.
6. Import the modified netlist into Designer. Again run compile and layout.
7. Invoke Timer again to review the delays for the signals of step 3.
8. If necessary, repeat steps 4 through 7 until the design timing requirements are met.

### ***Delay Values***

Rising (R) and falling (F) delays for INVD and BUFD in different Actel families can be found in the relevant datasheets. These values are obtained using the fastest speed grade for the device using typical



temperature, voltage, and process corners as well as optimized placement. Actual delay numbers may vary with the device, speed grade, and actual placement. Please visit our website at <http://www.actel.com/appnotes/BUFD.pdf> for the latest information.

## ALSPIN

Actel provides special input, output, tri-state, and bi-directional macros for adding I/Os to your design. Add the I/O macros to your design and connect them by nets to both port symbols, and the functional logic making up the design. Most third-party CAE tools have special symbols to represent the ports. Refer to the Actel Interface Guides for information about adding I/Os to your design.

**Note:** The ALSPIN property works only in pure schematic based designs in Designer. If your design is not purely schematic-based, use the ALSPIN property with the Synplify SCOPE tool.

Typically, pin assignments are made within Designer using PinEdit. However, many third-party CAE tools allow users to enter pin assignments directly into the design. The ALSPIN property may be added to the net connecting a port to an I/O buffer, shown in Figure 3-17. Assign the corresponding pin number as the value of the property. Most schematic capture tools pass the property to the netlist. Refer to the documentation provided with your schematic capture tools for more information about adding pin assignments.

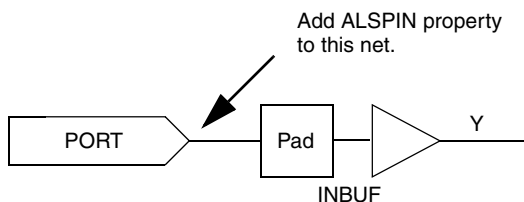

Figure 3-17. Adding ALSPIN Property to a Net

Example EDIF netlist:

```
(net N5 (joined (portRef PAD (instanceRefU3))
(portRef Y(instanceRef U3)))
(property ALSPIN (string "B2")))
```

```
(property ALSFIX (boolean (true))))))
```

### Selecting I/O Placements

The design flow for Actel FPGAs allows the following different methods of selecting I/O placements:

**Automatic pin assignment.** No manual assignment is made for an I/O signal. After you compile the design, run Layout and Designer automatically selects the best pin location depending on characteristics of the design, such as timing constraints, device type and package, and overall design topology.

**Manual pin assignment.** Manual pin assignments allow maximum control over the design flow, since the I/O assignments remain fixed regardless of design changes. You can use any of the following three methods to perform manual pin assignment, but Actel recommends that you use only one method.

- **Use PinEdit:** Refer to the *PinEdit User's Guide* for information about using PinEdit for manual pin assignment.
- **Assign pins from within the design schematic:** Designer allows you to assign and fix pins to I/O signals in your design schematic. For more information on how to assign pins from within the design schematic, refer to the Actel Interface Guide. You cannot back annotate pin assignments from Designer to your design schematic.
- **Import the <design>.pin file into Designer:** Designer can import pin files to assign pins. Refer to the *Designer User's Guide* for more information on how to import a file into Designer.

**Note:** For Axcelerator, the PDC file replaces the .pin file.

How you use the three methods above depends on the requirements of the project. You can get the final pin assignment by generating a pin report and/or printing the graphical view of the device pin assignment in PinEdit.

### Suggested I/O Assignment Method

Because both methods (automatic or manual) of determining I/O pin assignments for Actel devices can be used in combination, there are many methods to create quality pin placements. The best method for a design depends on factors such as scheduling constraints, design changes, and performance specifications.

To design effectively, use automatic pin assignment for 100% of the I/O signals. Designer optimizes the placement and routing, especially if it is given the flexibility of automatically assigning all I/O placements. Designer selects, evaluates, and optimizes many different I/O configurations specific to the device architecture. If as few as 10% of the pin assignments are inefficiently assigned manually, the quality of the placement and routing could be compromised. Fixed manual assignments should be kept to a minimum.

Automatic pin assignment may not be suitable for Axcelerator because of I/O bank assignments. Please see the PinEdit User's Guide for more information on I/O bank assignments.

## ***Fast I/O Assignment Procedure***

The I/O assignment process does not have to be a gating item to the overall system schedule. The optimal design flow would allow the software to reposition the I/O every design iteration. However, as long as I/O assignments change, PCB layout cannot take place, and the board may take several weeks to manufacture. To save time, as long as the number and function of the I/Os are finalized, use the following procedure to have Designer automatically assign all of the pins before the details of the design are completed and before the design is completely tested and debugged.

- 1. Enter the design as completely as possible, ignoring small details to be modified later.** It is important to include all of the major functions that will be in the FPGA circuit. The objective is to obtain a netlist that approximates the final design topology. The circuit does not need to be functionally correct at this point but must have the same major functional blocks (adders, counters, and so on) and approximately the same number of logic modules as the final design.
- 2. Layout the design in Designer.** Ignore any warnings from the Compile program that may be due to the unfinished state of the design. Run Layout in standard mode with incremental placement turned off.

At this point, Layout has automatically assigned I/Os according to the design topology. This is done before all of the functional bugs have been discovered and resolved. Minor functional changes that

may be made to the design will have little effect on the quality and effectiveness of the pin placements.

- 3. Layout the PCB.** Complete the PCB layout knowing that the pin assignments for the Actel device will not require modifications in the future.

Layout does not modify any I/O placements that have been fixed. This method can be used even if the I/Os are manually assigned. The results of automatic I/O assignment by Layout can be used as a template for manual I/O assignment. The automatic placements can be used as a guide and small modifications can be made as required.

## Assigning I/Os Manually

If any or all of the I/O placements must be assigned manually, a broader knowledge of Actel FPGA architecture is required. Refer to the Actel *FPGA Data Book* for information about different architectures of the Actel families. The structure of the logic and I/O modules, routing tracks, antifuses, and other architectural details are discussed. This information can be used to assign I/O signals manually with the specific details of the device in mind.

During the process of assigning I/Os for the device, the following guidelines can help to increase routability and performance:

- Try to force signal paths, especially large data buses, to flow horizontally across the die, since there are more horizontal than vertical routing resources. In most cases, a large data bus requires many interconnections as it traverses the circuit.

The greater number of horizontal routing tracks handles these interconnections to reduce routing congestion. The horizontal and vertical orientation of the die is the same as shown in the package pin assignment and mechanical detail drawings in the Actel *FPGA Data Book*.

### ***I/O Standard Compatability***

- Count the number of levels of logic between I/Os to determine placement. For example, I/Os that are separated by one gate should be placed closer than I/Os that are separated by a long shift register. In general, the Actel device architecture allows signals to be routed

across two vertical rows and over one-third of the columns of the device without using a long routing track. For example, an A1225 device that has 13 rows and 46 columns. Two I/O signals should not be placed on opposite sides of the device unless there are at least two horizontal or three vertical levels of logic between them.

- Use the top and bottom I/O pins for slow and/or local signals. The fact that there are fewer vertical routing resources should not harm the performance of these signals.
- Use the global clock buffers. Each of these pins is connected to a dedicated, low-skew distribution network that is optimized for high fanout signals.
- For Axcelerator, be sure make the assignments to I/O banks with the appropriate I/O technology.

### ***Unused I/O Pins***

Every I/O bond pad on the die is connected to a multipurpose circuit capable of becoming an input, output, or tri-state I/O. The circuit is always connected to the bond pad, and Designer configures it according to the design's specification. Refer to <http://www.actel.com/guru> and search the keyword "unused" for more information.

**Note:** This option is not available for Axcelerator devices.

### ***Using Probe Pins as I/O Pins***

Layout automatically avoids using the probe pins unless you have fixed pin assignments to one or more of these pins, or the number of pins in the design exceeds the number of non-probe I/O pins. The function of the probe pins depends on the JTAG mode Pin and Security Fuse Configuration. The availability and functionality of pins varies by device family. Please refer to the family-specific datasheets for precise data specifications (Axcelerator probe pins are dedicated). To use probe pins and JTAG pins as I/Os:

- Avoid using PRA or PRB as Input or Bidirectional pins, and
- Avoid using TDI/SDI, TCK/DCLK as Input or Bidirectional (using any of these pins in this way disables probing in the ACT1/40MX families)

### Using JTAG Pins as I/O Pins

The high-capacity devices of the 3200DX, 42MX, 54SX and 54SX-A families have four JTAG pins: “TDI,” “TMS,” “TCK” and “TDO.” Layout automatically avoids using these pins as I/O pins. If you are not using the JTAG function, you can use these pins as I/O pins except TMS. In addition, 54SX-A and eX families have a JTAG reset pin TRST. This pin can also be used as a user I/O if it is not used for the JTAG function. For Axcelerator, the JTAG pins are dedicated and cannot be used as I/O pins.

## Generating a Top-Level Symbol

You can create a top-level symbol for the entire design in your schematic entry tool. The pin names on the symbol must match the underlying port names. The top-level symbol must only contain pins for I/O buffers. Do not add power, ground, probe, or other special pins to the symbol. Doing so causes errors during netlist generation. Remember to update the symbol if pins change on the schematic.

## Entering Constraints for Timing Driven Place-and-route

Unique timing constraints for each signal path in a design can be specified using the Timer tool. It may only be necessary to specify the clock frequency for synchronous designs. The Timer mode typically eliminates time-consuming iterations of the design flow. Timing constraints can also be specified in a design constraint file and imported into Designer. Refer to the *Timer User's Guide* for information about specifying timing constraints in Timer, and the *Designer User's Guide* for information about importing a constraints file.

## Estimating Pre-Layout Timing

It is often necessary to estimate the timing of a design to be implemented prior to using the design tools. With some knowledge of the critical path, you can perform this analysis using the timing information in the Actel *FPGA Data Book*.

Figure 3-18 illustrates the procedure using an ACT 2 A1225XL-1 design example with a critical path from the CLK pad to the OUT pad. The delays used come from the timing tables for the A1225XL-1 in the Actel *FPGA Data Book*. These values include a statistical net delay which is associated with each macro output. The OUTBUF macro assumes a load of 35 pF. The analysis is based on worst case commercial conditions.

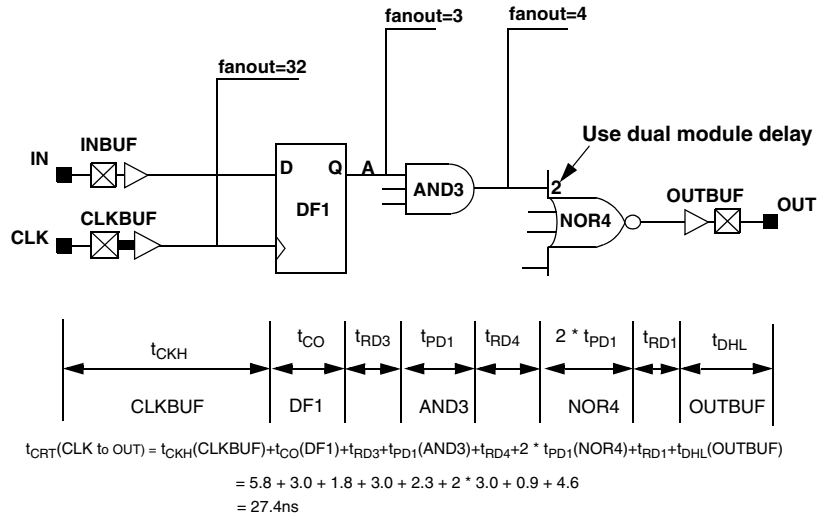

Figure 3-18. Critical Path Timing Example

**Note:** The “NOR4” macro has a significantly higher delay because it is a two-module macro.

## Adding ACTgen Macros

With the ACTgen Macro Builder, you can create macros using a simple graphical interface. For many schematic capture tools, a symbol and netlist description of the macro can be created directly from ACTgen. Other tools require a separate utility that uses third-party netlist readers to create a symbol and netlist description. Once the ACTgen symbol has been added to a schematic, the macro is added to the design's netlist during netlisting. Use the ACTgen Macro Builder to to configure the PLLs, RAM, FIFO, etc., for Axcelerator devices.



---

# ProASIC Design Considerations

This chapter contains information and procedures to assist you in creating Actel designs with ProASIC devices.

## Design Optimization

Use Designer report files and iterating tasks to optimize the design. When iterating only to optimize the design after a previously successful layout, all subsequent processing usually succeeds. If the design has only minor changes you can recycle the previous placement in an ECO mode and run placement refinement.

### Optimizing Inverters

If you run Designer with Netlist Optimization enabled, (default mode) inverters and buffers that do not limit fanout are removed from the design netlist. The removal of inverters is based on the use of internal inverted pins.

### Timing Optimization

Timing optimization is performed by iterating the design analysis and layout cycle on a design until it meets timing and layout requirements. Refer to the *Timer User's Guide* for additional information.

## Design Integrity

Designer offers a combination of safeguards that protect the integrity of a design, and the flexibility to override the safeguards when necessary. Designer keeps track of a design project and ensures that the design flow is followed to maintain the integrity of the project database and to keep it synchronized with the design state.

By default the system performs tasks in the order shown in the task list, using the results from each step as input for the next step. Additionally, only tasks required to produce the stated outputs are performed and you are prompted for required inputs for each task.

Although Designer performs tasks in a specific order, the system can perform a subset of these operations to suit the current design state unless an operation violates one of the safeguards.

For example, if a design is placed and routed but post-layout delays violate timing requirements, Designer can be directed to only optimize place and route and recalculate the delays. File checking or any other task previously done is not repeated unless any of the input files have also changed between runs.

Designer processes a design incrementally by default. It keeps track of successfully completed tasks and does not repeat them. If data for a task are missing, the system either automatically supplies it or prompts the user to supply the needed information.

## Design Hints

The design netlist is the main input for Designer. When creating a design, device usage and Designer features can be maximized by using the following guidelines:

- Use the automatic global resource assignments specified by Designer and, if appropriate, add constraints.
- Use the automatic mapping that Designer specifies between package pins and a design's I/O signals and, if appropriate, add constraints.
- Avoid over constraining a design so that Designer can apply its algorithms to the best advantage for place-and-route.
- Implement tristates, memories, and hierarchical blocks with Designer-supported elements.
- Avoid asynchronous designs. They are difficult to verify, are less robust, and typically include problems such as hazard and race conditions.
- When gating clocks, ensure that the gate signals are stable when the clock is active. Otherwise, glitches might be propagated through the circuit.
- Use a minimum of logic before the first flip-flop or after the last flip-flop on signals that are to be driven on or off chip to provide as much

time as possible to drive the signal off the chip and onto the next chip.

- Ensure that process variations do not adversely affect reliability, always design with worst-case processes in mind.

## *Implementing Memories*

All ProASIC devices support embedded memories. Synchronous or asynchronous two port RAMs and FIFOs can be generated by ACTgen and imported into the synthesis and simulation environments. Designer also supports distributed memories. Although this implementation of memories is much less efficient in terms of gate utilization, it may be appropriate for smaller memories in a design.



---

## *Product Support*

Actel backs its products with various support services including Customer Service, a Customer Technical Support Center, a web site, an FTP site, electronic mail, and worldwide sales offices. This appendix contains information about contacting Actel and using these support services.

### *Actel U.S. Toll-Free Line*

Use the Actel toll-free line to contact Actel for sales information, technical support, requests for literature, Customer Service, investor information, and using the Action Facts service.

The Actel toll-free line is (888) 99-ACTEL.

### *Customer Service*

Contact Customer Service for non-technical product support, such as product pricing, product upgrades, update information, order status, and authorization.

From Northeast and North Central U.S.A., call (408) 522-4480.

From Southeast and Southwest U.S.A., call (408) 522-4480.

From South Central U.S.A., call (408) 522-4434.

From Northwest U.S.A., call (408) 522-4434.

From Canada, call (408) 522-4480.

From Europe, call (408) 522-4252 or +44 (0) 1276 401500.

From Japan, call (408) 522-4743.

From the rest of the world, call (408) 522-4743.

Fax, from anywhere in the world (408) 522-8044.

### *Actel Customer Technical Support Center*

Actel staffs its Customer Technical Support Center with highly skilled engineers who can help answer your hardware, software, and design questions. The Customer Technical Support Center spends a great deal of time creating application notes and answers to FAQs. So, before you contact us, please visit our online resources. It is very likely we have already answered your questions.

## *Guru Automated Technical Support*

Guru is a web-based automated technical support system accessible through the Actel home page (<http://www.actel.com/guru/>). Guru provides answers to technical questions about Actel products. Many answers include diagrams, illustrations, and links to other resources on the Actel web site.

## *Web Site*

Actel has a World Wide Web home page where you can browse a variety of technical and non-technical information. The URL is <http://www.actel.com>.

## *Contacting the Customer Technical Support Center*

Highly skilled engineers staff the Technical Support Center from 7:00 A.M. to 6:00 P.M., Pacific Time, Monday through Friday. Several ways of contacting the Center follow:

### ***Electronic Mail***

You can communicate your technical questions to our e-mail address and receive answers back by e-mail, fax, or phone. Also, if you have design problems, you can e-mail your design files to receive assistance. We constantly monitor the e-mail account throughout the day. When sending your request to us, please be sure to include your full name, company name, and your contact information for efficient processing of your request.

The technical support e-mail address is **tech@actel.com**.

## ***Telephone***

Our Technical Support Center answers all calls. The center retrieves information, such as your name, company name, phone number and your question, and then issues a case number. The Center then forwards the information to a queue where the first available application engineer receives the data and returns your call. The phone hours are from 7:00 A.M. to 6:00 P.M., Pacific Time, Monday through Friday. The Technical Support numbers are:

***(408) 522-4460***

***(800) 262-1060***

Customers needing assistance outside the US time zones can either contact technical support via email ([tech@actel.com](mailto:tech@actel.com)) or contact a local sales office. Please see our list of [Worldwide Sales Offices](#).

## Worldwide Sales Offices

### Headquarters

Actel Corporation  
955 East Arques Avenue  
Sunnyvale, California 94086  
Toll Free: 888.99.ACTEL  
Tel: 408.739.1010  
Fax: 408.739.1540

### US Sales Offices

#### California

Bay Area  
Tel: 408.328.2200  
Fax: 408.328.2358

Irvine  
Tel: 949.727.0470  
Fax: 949.727.0476

Newbury Park  
Tel: 805.375.5769  
Fax: 805.375.5749

#### Colorado

Tel: 303.420.4335  
Fax: 303.420.4336

#### Florida

Tel: 407.977.6846  
Fax: 407.977.6847

#### Georgia

Tel: 770.277.4980  
Fax: 770.277.5896

#### Illinois

Tel: 847.259.1501  
Fax: 847.259.1575

#### Massachusetts

Tel: 978.244.3800  
Fax: 978.244.3820

#### Minnesota

Tel: 651.917.9116  
Fax: 651.917.9114

#### New Jersey

Tel: 609.517.0304

#### North Carolina

Tel: 919.654.4529  
Fax: 919.674.0055

#### Pennsylvania

Tel: 215.830.1458  
Fax: 215.706.0680

#### Texas

Tel: 972.235.8944  
Fax: 972.235.9659

### International Sales Offices

#### Canada

235 Stafford Rd. West, Suite 106  
Nepean, Ontario K2H9C1, Canada  
Tel: 613.726.7575  
Fax: 613.726.8666

#### France

361 Avenue General de Gaulle  
92147 Clamart Cedex  
Tel: +33 (0)1.40.83.11.00  
Fax: +33 (0)1.40.94.11.04

#### Germany

Lohweg 27,  
D-85375 Neufahrn  
Germany  
Tel: +49.(0)81.659.584.0  
Fax: +49.(0)81.659.584.10

#### Italy

Via dei Garbaldini 5  
20019 Settimo Milanese  
Milano, Italy  
Tel: +39 (0)2.3809.3259  
Fax: +39 (0)2.3809.3260

#### Japan

EXOS Ebisu Building 4F  
1-24-14 Ebisu Shibuya-ku  
Tokyo 150  
Tel: +81 (0)3.3445.7671  
Fax: +81 (0)3.3445.7668

#### Korea

30th floor, ASEM Tower,  
159-1 Samsung-dong,  
Kangnam-ku, Seoul, Korea  
Tel: +82 (0)2.6001.3382  
Fax: +82 (0)2.6001.3030

#### United Kingdom

Maxfli Court  
Riverside Way  
Camberley, Surrey  
GU15 3YL  
United Kingdom  
Tel: +44 (0)1276.401450  
Fax: +44 (0)1276.401490



---

# Index

<act\_fam> variable 8  
<vhd\_fam> variable 8

## A

Actel 8  
  Device Families 8  
  Libraries 29  
  web site 62  
  web-based technical support 62  
Actel Manuals 9  
ACTgen Macro Builder 56  
Adding  
  Global Networks 30  
  Ground 29  
  Pins 49  
  Power 29  
  Properties 44  
Adding ACTgen Macros 56  
ALSPIN 49  
Assumptions 8  
Asynchronous designs 58  
Automatic  
  Fan-In Reduction 34  
  Logic Reduction 34  
  Module Reduction 34  
  Pin Assignment 50  
Automatic mapping 58

## B

Back Annotation  
  Effects of Combiner 39  
Buffering 34, 43

## C

Calculating Module Utilization 44  
Capturing a Design

  HDL-Based 22  
  Schematic-Based 18  
Checker  
  checker log 34  
CLK 32  
CLKA 32  
CLKB 32  
Clock  
  Dedicated 32  
  Routed 32  
Combinatorial Module Reduction 35  
Combiner 34  
  Back Annotation Effects 39  
Combining Modules 34  
  40MX 41  
  ACT 1 41  
Compile 11  
Constant Input Reduction 38  
Contacting Actel  
  customer service 61  
  electronic mail 62  
  telephone 63  
  toll-free 61  
  web-based technical support 62  
Conventions 8  
  <act\_fam> variable 8  
  <vhd\_fam> variable 8  
Customer service 61

## D

DCLK 53  
Dedicated Clocks 32  
  HCLK 32  
  IOCLK 33  
Delay  
  Estimating 54

- Design
  - netlist 58
- design
  - practices 58
- Design Creation/Verification 18, 22
  - EDIF Netlist Generation 19, 23
  - Functional Simulation 18, 22
  - HDL Source Entry 22
  - Schematic Capture 18
  - Structural Netlist Generation 23
  - Structural Simulation 23
  - Synthesis 23
- Design Flow
  - Design Creation/Verification 18, 22
  - Design Implementation 19
  - Schematic-Based 17–20
  - Synthesis-Based 21–23
- Design Implementation 19
  - Place-and-Route 19
  - Power Analysis 19
  - Timing Simulation 19
- Design Layout 19
- Design Optimization, ProASIC 57
- Design Synthesis 23
- Designer
  - Overview 11–15
  - Place-and-Route 19
  - Timing Analysis 19
- Designer Maintenance 15
- Designs
  - Hierarchical 29
  - Multiple Sheet 29
- Device
  - Families 8
  - Programming 19, 20
  - Verification 20, 23

- Document Assumptions 8
- Document Conventions 8
- Document Organization 7
- Duplicating Logic 43

**E**

- EDIF Netlist Generation
  - Schematic-Based 19
  - Synthesis-Based 23
- Electronic mail 62, 63
- Embedded memories 59
- Estimating Delays 54

**F**

- Fan Out 43
- Fan-In Reduction 34, 39
- Functional Simulation 18, 22
- Fuse 13

**G**

- Gate-Level Netlist 23
- Gating clocks 58
- Generating 54
  - EDIF Netlist 19, 23
  - Gate-Level Netlist 23
  - Structural Netlist 23
- Global Network 30
- GND 29
- Ground 29

**H**

- HCLK 32
- HDL Source Entry 22
- Hierarchical
  - Designs 29
- Hierarchical blocks 58

High Fan Out 43  
High fanout signals 34

## I

I/O  
    Clock 33  
    Module Utilization 44  
IOCLK 33  
IOPCL 33

## J

JTAG Pins 54

## L

Layout 12  
    Standard 12  
    Timing Driven 12  
Libraries 29  
Logic Module Utilization 44  
Logic Reduction 34, 38

## M

Maintenance Mode 15  
Manual Pin Assignment 50  
Memories  
    embedded 59  
Module Reduction 34  
    40MX 41  
    ACT 1 41  
    Combinatorial 35  
Multiple Sheet Designs 29

## N

Naming Conventions  
    Schematic 25  
    Verilog 27

VHDL 25

Net

    Loading 43  
Netlist Generation  
    EDIF 19, 23  
    Gate-Level 23  
    Structural 23  
Network 30

## O

Online Help 9

## P

Pin

    Adding 49  
    Assignment 49–54  
    Automatic Assignment 50  
    DCLK 53  
    JTAG 54  
    PRA 53  
    PRB 53  
    Probe 53  
    SDI 53  
    TCK 54  
    TDI 54  
    TDO 54  
    TMS 54  
    Unused I/O 53  
PinEdit 13  
Place-and-Route 19  
Power 29  
Power Analysis 19  
PRA 53  
PRB 53  
Preserving Macros 44  
ProASIC

- global routing resources 34
- Probe Pins 53
- Product support 61–64
  - customer service 61
  - electronic mail 62, 63
  - toll-free line 61
  - technical support 62
  - web site 62
- Programming a Device 20
- Property, ALSPRESERVE 44

## R

- Remapping 36
- Routed Clocks 32
  - CLK 32
  - CLKA 32
  - CLKB 32
  - QCLK 32

## S

- Schematic Capture 18
- Schematic-Based Design Flow 17–20
  - Design Creation/Verification 18
  - Design Implementation 19
  - Programming 19, 20
  - System Verification 20
- SDI 53
- Sequential Remapping 36
- Simulation
  - Functional 18, 22
  - Schematic-Based 18, 19
  - Structural 23
  - Synthesis-Based 22, 23
  - Timing 19
- SmartPower 19
- Special Clocks 33

- IOPCL 33
- Static Timing Analysis 19
- Structural Netlist Generation 23
- Structural Simulation 23
- Symbol, Top Level 54
- Synthesis 23
- Synthesis-Based Design Flow 21–23
  - Design Creation/Verification 22
  - System Verification 23
- System Verification 20, 23
  - Silicon Explorer II 20, 23

## T

- TCK 54
- TDI 54
- TDO 54
- Timer 14
- Timer Tool 19
- Timing 12
- Timing Analysis 19
- Timing Constraint 54
- Timing Simulation 19
- TMS 54
- Toll-free line 61
- Top Level Symbol 54

## U

- Unit Delays 18, 22
- Unused Logic Removal 38
- Utilization 44

## V

- variables
  - <act\_fam> 8
  - <vhd\_fam> 8
- VCC 29

---

W

Web-based technical support 62

